

Job: \_\_\_\_\_

Item: \_\_\_\_\_

Quantity: \_\_\_\_\_

## Wet Produce Cart

These carts help minimize the mess of transporting produce by retaining moisture and debris. These carts have two reinforced removable drip pans to help remove unwanted moisture and help keep work areas clean.

- Framework is constructed out of 1½" x 2" x .070" wall tubing.
- Handle and uprights are constructed out of 1 5/16" diameter pipe.
- Removable drip trays are constructed out of .063" aluminum sheet and they are reinforced with ¾" x 1 5/16" x .100" wall.
- Full perimeter bumper on the top shelf is standard.
- Equipped with six 5" platform type casters, four swivel and two rigid.
- Five-Year Guarantee against material defects and workmanship.
- Lifetime Guarantee against rust and corrosion.
- NSF Certified.



1408 - 1410



Model No	Size W-H-L	Weight Capacity	No. Casters	Top Shelf Height	Shelf Spacing	Ship Lbs.
<b>Carts w/ Two (2) Removable Pans</b>						
1408	21" x 41" x 48½"	1200 lbs.	6	30"	19¼"	64
1410	29" x 41" x 50½"	1000 lbs.	6	30"	19¼"	69

Above units come equipped with a full perimeter bumper on the top shelf.

Six 5" platform type casters — four swivel (#C450) two rigid (#C460).

**Options:**

**"CL(B)"** — See catalog for details.

**Rear Mount Basket** - Add "RMB" suffix to model #.

**Paper Towel Bracket** - Add "PTB" suffix to model #.

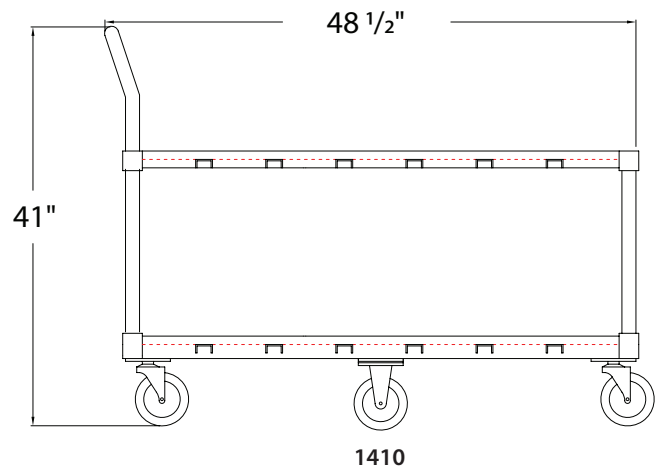

*This information is for general sales and engineering use only. New Age Industrial reserves the right to modify or make changes at any time without notice to materials and specifications.*

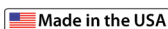

Distributed by: