

Job: \_\_\_\_\_

Item: \_\_\_\_\_

Quantity: \_\_\_\_\_

## Utility/Bussing Cart

Designed for various tasks such as serving, bussing, and general utility, these three shelf units have three lips up and on lip down to help hold products on shelves.

- Framework is constructed of 1" x 1" x .070" wall tubing.
- Shelves are constructed of .080" aluminum sheet.
- Equipped with four 5" stem type swivel casters.
- Five-Year Guarantee against material defects and workmanship.
- Lifetime Guarantee against rust and corrosion.
- NSF Certified.



NS745

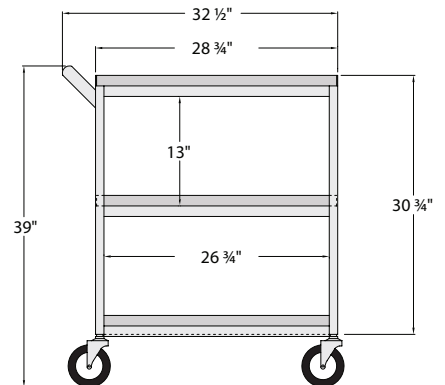
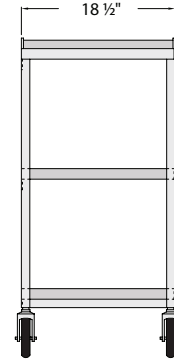

Model No.	Size W-H-D	Shelf Size	Shelf Spacing	Weight Cap.	Ship Lbs.
<b>3-Tier</b>					
NS745	18½" x 39" x 32½"	18½" x 28¾"	13"	350 lbs.	35
1440	16½" x 39" x 27¾"	16½" x 24"	13"	350 lbs.	29

Four 5" stem type casters— two swivel (#C480) two w/ brake (#C485).  
 Each shelf with three sides up 1¼" and one side down 1¼".

**Options: "B", "MD", "VB"** — see catalog for details.

*This information is for general sales and engineering use only. New Age Industrial reserves the right to modify or make changes at any time without notice to materials and specifications.*

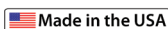

Distributed by: