

Project: \_\_\_\_\_

Item: \_\_\_\_\_

Quantity: \_\_\_\_\_

## Mat Carts



**99360**  
All-Welded Cart

Labor saving mobile mat carts keep mats off of the floor for easy, efficient cleaning.

- Hooks secure perforated mats for storage and cleaning.
- Center horizontal bars hold solid mats. *(all welded unit only)*
- Open design allows use of waste container. *(K.D. model only)*
- Ideal for power washing mats on the cart.
- Lifetime Guarantee against rust and corrosion.



**51087**  
Knocked Down Cart

### ► Mat Cart

Model No.	Size W-H-D	Weight Capacity	Ship Lbs.
<b>All Welded</b>			
99360	41½" x 40" x 27½"	500 lbs.	40
Four 5" plate type swivel casters; two (#C450), two with brake (#C455).			
<b>Knocked Down</b>			
51087	24" x 45¼" x 36"	500 lbs.	37
Four 5" plate type casters, swivel with brake (#C455).			



New Age Industrial Corp., Inc. || [NewAgeIndustrial.com](http://NewAgeIndustrial.com) || Made in the USA

PO Box 520 • 16788 US Hwy 36 • Norton, Kansas 67654 || Phone: (800) 255-0104 • (785) 877-5121 || Fax: (877)-877-7687 • (785) 877-2616

This information is for general sales and engineering use only. New Age Industrial reserves the right to modify or make changes at any time, without notice, to materials and specifications.

Project: \_\_\_\_\_

Item: \_\_\_\_\_

Quantity: \_\_\_\_\_

## Mat Carts & Rack

### MATERIAL:

- Framework is constructed out of 1" x 1" x .070" wall tubing.
- Mat hangers are constructed out of 5/8" diameter aluminum rod.

### CASTERS:

- Equipped with four 5" platform type swivel casters, two with brake.

### GUARANTEES:

- Lifetime Guarantee against rust and corrosion.
- Five-Year Guarantee against workmanship and material defects.

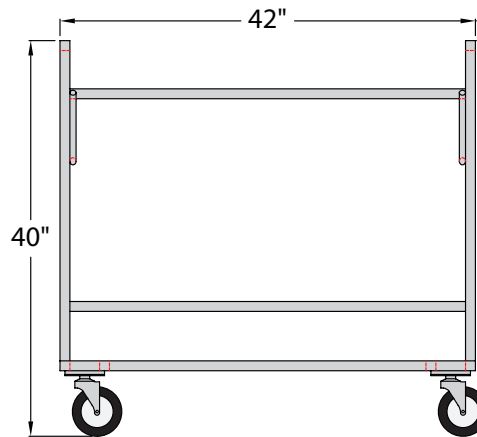

**99360**  
All-Welded Cart

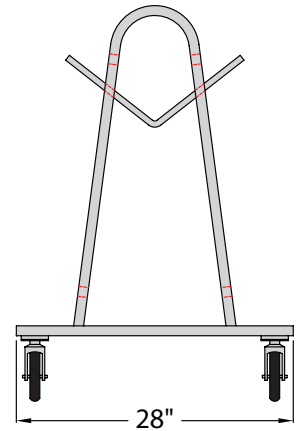

### MATERIAL:

- Framework is constructed out of 1 1/2" x 2" x .070" wall tubing.
- Collars welded in place to accept 1 1/2" diameter pipe uprights.
- Mat hangers are constructed out of 5/8" diameter aluminum rod.

### CASTERS:

- Equipped with four 5" platform type swivel casters with brakes.

### GUARANTEES:

- Lifetime Guarantee against rust and corrosion.
- Five-Year Guarantee against workmanship and material defects.

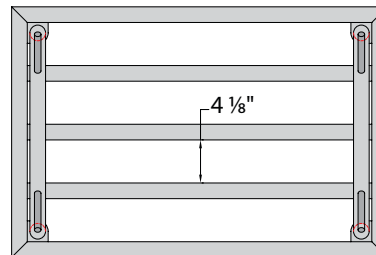

**51087**  
Knocked Down Cart

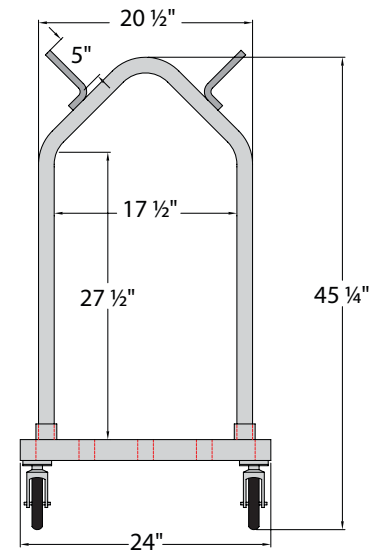
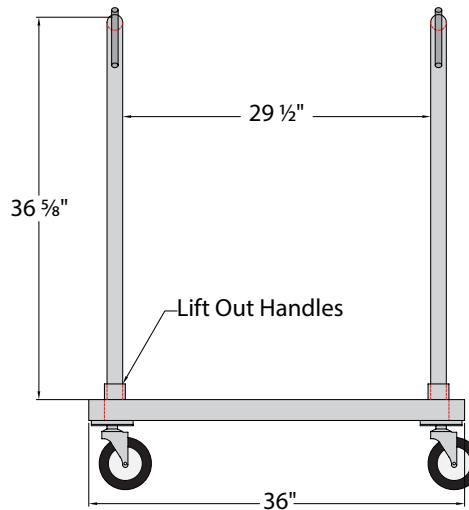

New Age Industrial Corp., Inc. || [NewAgeIndustrial.com](http://NewAgeIndustrial.com) || Made in the USA

PO Box 520 • 16788 US Hwy 36 • Norton, Kansas 67654 || Phone: (800) 255-0104 • (785) 877-5121 || Fax: (877)-877-7687 • (785) 877-2616

This information is for general sales and engineering use only. New Age Industrial reserves the right to modify or make changes at any time, without notice, to materials and specifications.